

PROPRIETARY AND CONFIDENTIAL

THE INFORMATION CONTAINED IN THIS DRAWING IS THE SOLE PROPERTY OF DYTRAN INSTRUMENTS INC. ANY REPRODUCTION IN PART OR AS A WHOLE WITHOUT THE WRITTEN PERMISSION OF DYTRAN INSTRUMENTS INC. IS PROHIBITED

REVISIONS

REV.	ECN	DESCRIPTION	BY/DATE	CHK	APPR
B	5839	.31 WAS: .24	JS 03/12/09	RA	DV
C	8563	ADDED "MADE IN USA" MARKING	JS 04/27/12	LN	DV
D	9573	ADDED MOUNTING SCREW DYTRAN MODEL 6868 (2 PROVIDED)	RA, 02/08/13	LN	DV
E	11218	ADDED NOTE 2 & 2X 6688 M3 SCREW	EC 08/08/14	JS	EP
F	13122	ADDED: NOTE 3; AND ZONE B4 DRAWING REFERENCE	LA 12/02/16	RA	LN
G	13283	ZONE C4 ADDED: .22 [5.6], ZONE B4 ADDED: .44 [11.2] & .15 [3.8]	LA 02/20/17	RA	LN

MODEL NO.	REV	ECN	DATE	RANGE
7500A1	G	13283	02/20/17	2g
7500A2	G	13283	02/20/17	5g
7500A3	G	13283	02/20/17	10g
7500A4	G	13283	02/20/17	25g
7500A5	G	13283	02/20/17	50g
7500A6	G	13283	02/20/17	100g
7500A7	G	13283	02/20/17	200g
7500A8	G	13283	02/20/17	400g

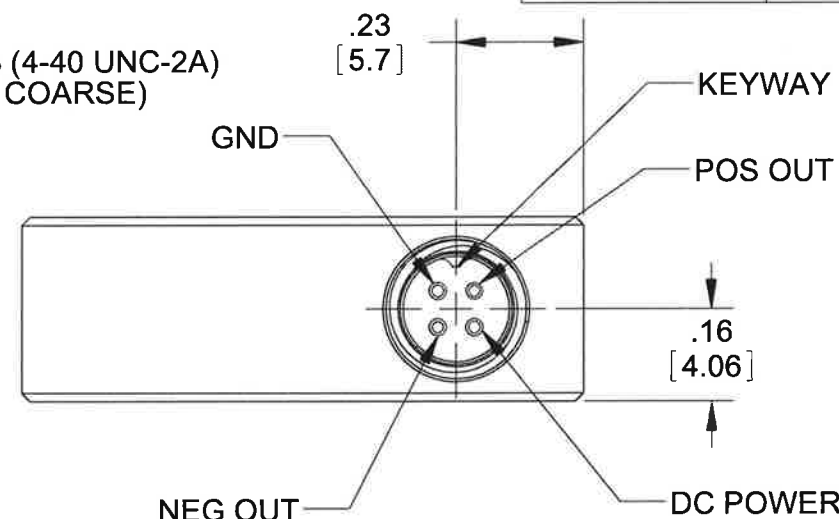
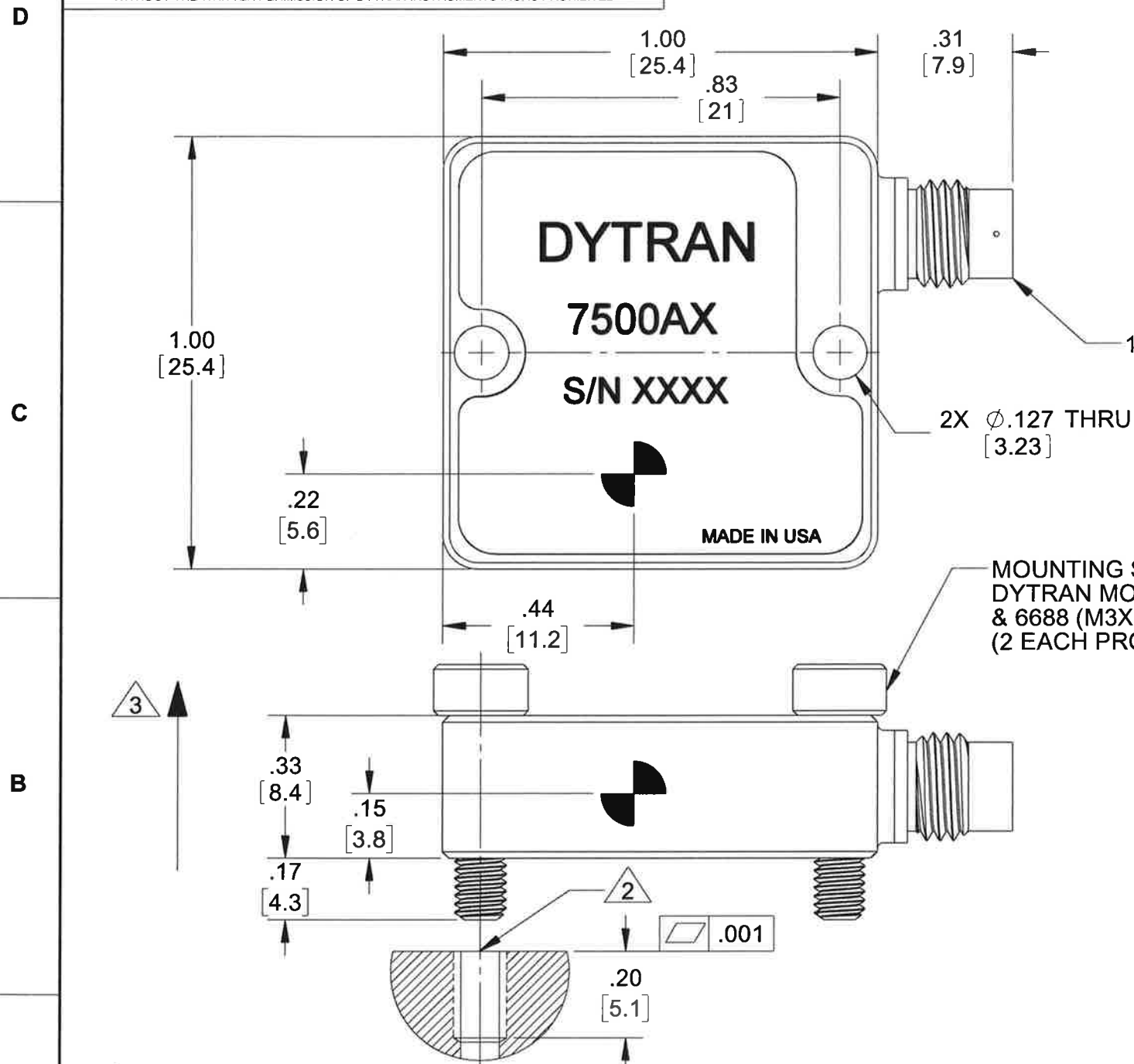

3 ARROW INDICATES DIRECTION FOR POSITIVE OUTPUT.

2 MOUNTING RECOMMENDATIONS:
PREPARE A SURFACE TO A FLATNESS EQUAL OR BETTER THAN .0001 TIR. TAP 4-40 UNC-2B ∇.200 MIN. OR TAP M3X.5 ISO 6H COARSE ∇5.1 MIN. RECOMMENDED TORQUE 10-12 LB-IN.

1. DIMENSIONS IN BRACKETS [X.XX] ARE IN MILLIMETERS.

NOTES: UNLESS OTHERWISE SPECIFIED

<small>UNLESS OTHERWISE SPECIFIED: INTERPRET DIM & TOL PER ASME Y14.5M - 1994. REMOVE BURRS. COUNTERSINK INTERNAL THDS 90° TO MAJOR DIA. CHAM EXT THDS 45° TO MINOR DIA. THD LENGTHS AND DEPTHS ARE FOR MIN FULL THDS. DIMENSIONS APPLY AFTER FINISHING.</small>	<small>UNLESS OTHERWISE SPECIFIED: DIMENSIONS ARE IN INCHES. DIMENSIONS IN BRACKETS [] ARE IN MILLIMETERS TOLERANCES ARE:</small>			
	<small>DECIMALS .XX ±.03 .XXX ±.010</small>	<small>METRIC .X ± 0.8 .XX ± 0.25</small>		
	APPROVALS		DATE	
	<small>ORIG</small> TMD	<small>CHK</small> CES	<small>APP</small> CES	<small>DATE</small> 05/23/07
<small>ALL MACHINED SURFACES. TOTAL RUNOUT WITHIN .005. BREAK SHARP EDGES .005 TO .010. MACHINED FILLET RADII .005 TO .015. WELDING SYMBOLS PER AWS A2.4. ABBREVIATIONS PER MIL-STD-12.</small>		<small>DO NOT SCALE DRAWING</small>	<small>THIRD ANGLE PROJECTION USA</small>	TITLE: OUTLINE/INSTALLATION DRAWING, VARIABLE CAPACITANCE ACCELEROMETER
<small>SIZE</small> B	<small>CAGE CODE</small> 2W033	<small>DWG NO</small> 127-7500A	<small>REV</small> G	
<small>SCALE: 4:1</small>		<small>SHEET 1 OF 1</small>		



- **VARIABLE CAPACITANCE ACCELEROMETER**
- **DIFFERENTIAL MODE**
- **HERMETICALLY SEALED**
- **DC RESPONSE**

		ENGLISH		SI	
PHYSICAL					
Weight, Max		0.46	oz	13	grams
Connector	Type	4-PIN, 1/4-28 UNF-2A		4-PIN, 1/4-28 UNF-2A	
Mounting	Thru Holes	2 X Ø.13		2 X Ø.13	
Material		Titanium Alloy		Titanium Alloy	
PERFORMANCE					
Input Range		±50	g	±490.5	m/s ²
Frequency Response (±5%)		0 - 1200	Hz	0 - 1200	Hz
Frequency Response (±3dB)		0 - 2000	Hz	0 - 2000	Hz
Resonant Frequency		>4000	Hz	>4000	Hz
Sensitivity Differential, ±10% [1]		40	mV/g	4.1	mV/m/s ²
Output Noise, Differential, Typ.		50	µ g rms/√ Hz	491	µ m/s ² /√ Hz
Non-Linearity, Max. [3]		0.5	% Span	0.5	% Span
Transverse Sensitivity, Max.		3	%	3	%
Scale Factor Calibration Error, Max.		1	%	1	%
ENVIRONMENTAL					
Maximum Mechanical Shock		5000	gpk	49050	m/s ² peak
Bias Temperature Shift, Max. [2]		111	(ppm of span)/°F	200	(ppm of span)/°C
Bias Calibration Error		0.5	% of span	0.5	% of span
Operating Temperature Range		-67 to +257	°F	-55 to +125	°C
Scale Factor Temperature Shift [2]		-111 to +111	ppm/°F	-200 to +200	ppm/°C
Seal		Hermetic		Hermetic	
ELECTRICAL					
Output Common Mode Voltage, Typ.		2.45	VDC	2.45	VDC
Output Impedance, Nom.		1	Ω	1	Ω
Operating Voltage		+9 to +32	VDC	+9 to +32	VDC
Operating Current (AOP & AON open)		12 to 14	mA DC	12 to 14	mA DC
Power Supply Rejection Ratio		>65	dB	>65	dB
Ground Isolation		>30	MΩ	>30	MΩ

This family also includes:

Model	Input Range (g)	Frequency Response, ±3dB (Hz)	Sensitivity Differential, ±10% (mV/g)	Max. Shock (gpk)	Noise Differential (µg rms/√Hz)
7500A1	± 2	0-400	1,000	2000	7
7500A2	± 5	0-500	400	2000	12
7500A3	± 10	0-1000	200	5000	18
7500A4	± 25	0-1400	80	5000	25
7500A6	± 100	0-2500	20	5000	100
7500A7	± 200	0-3000	10	5000	200
7500A8	± 400	0-4000	5	5000	400

Refer to the performance specifications of the products in this family for detailed description.

Supplied Accessories:

- 1) Accredited calibration certificate (ISO 17025)
- 2) Two mounting screws model # 6868 (SHCS, 4-40 X .50)
- 3) Two mounting screws model # 6888 (SHCS, M3 X 0.5 MM)

Notes:

- [1] Single ended sensitivity is half of values shown.
- [2] Over the rated temperature range.
- [3] -90% to +90% of Full Scale.
- [4] In the interest of constant product improvement, we reserve the right to change specifications without notice.

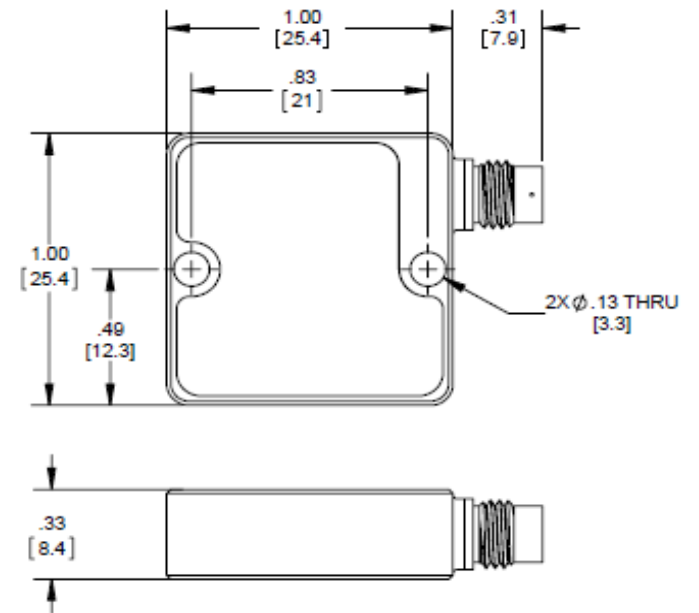

Units on the line drawing are in inches, dimensions in brackets [] are in millimeters. Refer to 127-7500A for more information.

