

PROPRIETARY AND CONFIDENTIAL

THE INFORMATION CONTAINED IN THIS DRAWING IS THE SOLE PROPERTY OF DYTRAN INSTRUMENTS INC. ANY REPRODUCTION IN PART OR AS A WHOLE WITHOUT THE WRITTEN PERMISSION OF DYTRAN INSTRUMENTS INC. IS PROHIBITED

REVISIONS

REV.	ECN	DESCRIPTION	BY/DATE	CHK	APPR
D	13677	REVISED PIN-OUT. PIN 2: AOPX(+X) WAS: AONX (-X) PIN 3: AONX(-X) WAS: AOPX (+X) PIN 4: AOPY(+Y) WAS: AONY (-Y) PIN 5: AONY(-Y) WAS: AOPY (+X) PIN 6: AOPZ(+Z) WAS: AONY (-Z) PIN 7: AONZ(-Z) WAS: AOPY (+Z)	LN 8/17/17	MH	

MODEL	INPUT RANGE, X & Y AXES	INPUT RANGE, Z AXIS
7503D1	±2g	±2g
7503D2	±5g	±5g
7503D3	±10g	±10g
7503D4	±25g	±25g
7503D5	±50g	±50g
7503D6	±100g	±100g
7503D7	±200g	±200g
7503D8	±400g	±400g
7503D9	±5g	±25g
7503D10	±5g	±50g

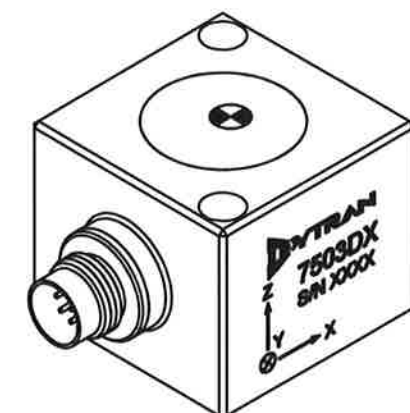
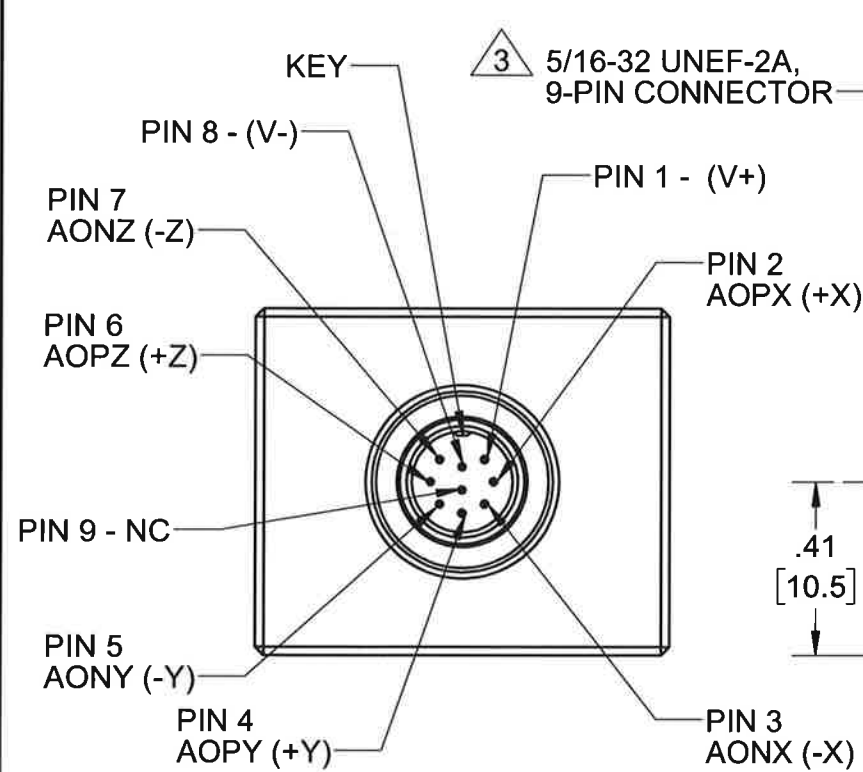
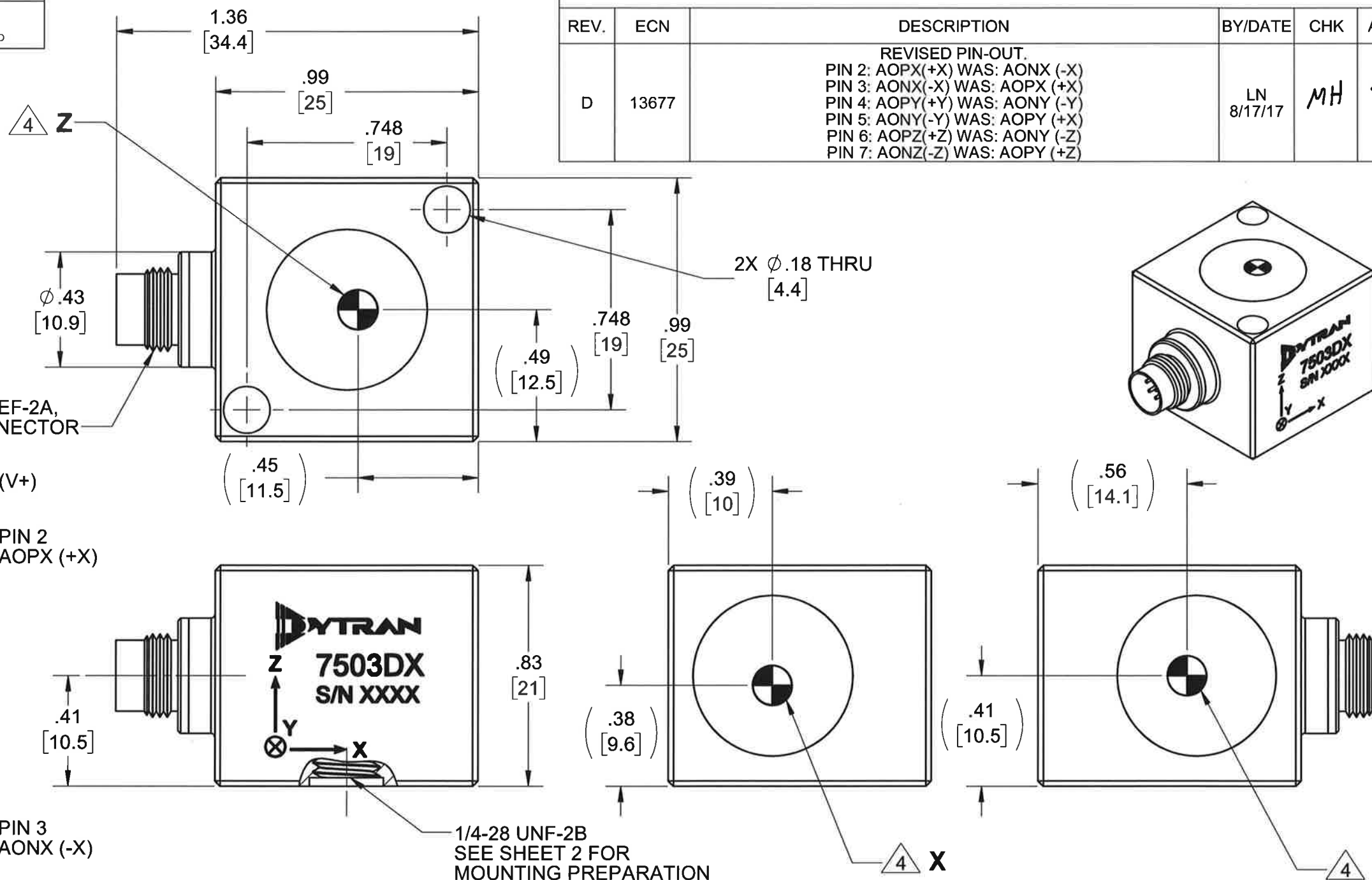

5. MINOR VOIDS, SCARS, SCRATCHES AND MOUNTING BLEMISH/WITNESS MARKS ON EXTERIOR SURFACES ARE ALLOWED DUE TO RESTRAINING AND HANDLING DURING TESTING, TRANSPORT OR PROCESSING. THESE APPEAR AS INDICATORS THAT DO NOT AFFECT FORM, FIT OR FUNCTION AS INTENDED BY DESIGN OR APPLICATION

4 MARKING DENOTES LOCATION OF SENSING ELEMENT'S CENTER OF MASS

3 MATES WITH DYTRAN 6964AXX CABLE (XX DENOTES LENGTH IN FT)

2. WEIGHT: 38 GRAMS, MAX.

1. MATERIAL: TITANIUM ALLOY.

NOTES: UNLESS OTHERWISE SPECIFIED

UNLESS OTHERWISE SPECIFIED:  
INTERPRET DIM & TOL PER ASME Y14.5M - 1994.  
REMOVE BURRS.  
COUNTERSINK INTERNAL THDS 90° TO MAJOR DIA.  
CHAM EXT THDS 45° TO MINOR DIA.  
THD LENGTHS AND DEPTHS ARE FOR MIN FULL THDS.  
DIMENSIONS APPLY AFTER FINISHING.

ALL MACHINED SURFACES.  
TOTAL RUNOUT WITHIN .005.  
BREAK SHARP EDGES .005 TO .010.  
MACHINED FILLET RADII .005 TO .015.  
WELDING SYMBOLS PER AWS A2.4.  
ABBREVIATIONS PER MIL-STD-12.

UNLESS OTHERWISE SPECIFIED:  
DIMENSIONS ARE IN INCHES.  
DIMENSIONS IN BRACKETS [ ] ARE IN MILLIMETERS TOLERANCES ARE:

DECIMALS	METRIC	ANGLES
.XX ±.03	.X ± 0.8	±1°
.XXX ±.010	.XX ±0.25	

APPROVALS		DATE
ORIG	LN	12/01/14
CHK	JS	02/12/15
APP	DV	02/16/15
DO NOT SCALE DRAWING		THIRD ANGLE PROJECTION USA



TITLE: **OUTLINE/INSTALLATION DWG, TRIAXIAL DC ACCELEROMETER, 7503D SERIES**

SIZE	CAGE CODE	DWG NO	REV
B	2W033	127-7503D	D
SCALE: 1:1	SHEET 1 OF 2		

**PROPRIETARY AND CONFIDENTIAL**

THE INFORMATION CONTAINED IN THIS DRAWING IS THE SOLE PROPERTY OF DYTRAN INSTRUMENTS INC. ANY REPRODUCTION IN PART OR AS A WHOLE WITHOUT THE WRITTEN PERMISSION OF DYTRAN INSTRUMENTS INC. IS PROHIBITED

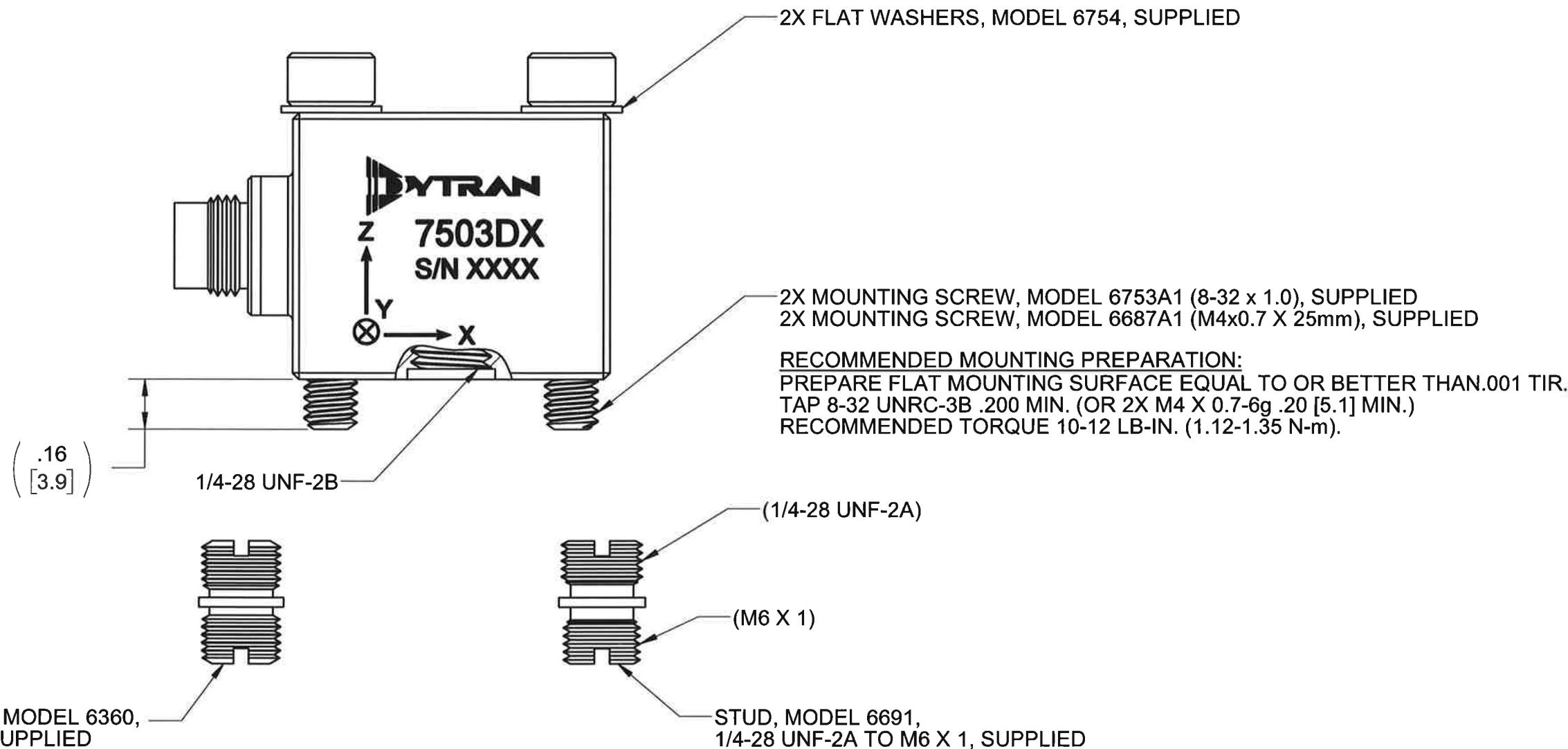

**RECOMMENDED MOUNTING PREPARATION: MODEL 6360**  
PREPARE MOUNTING SURFACE,  $\phi 1.25$  [31.2] MIN, FLAT TO .001 TIR.  
TAP 1/4-28 UNF-2B  $\nabla .200$  [5.1] MIN. TORQUE TO 12-15 Lb-in.

**RECOMMENDED MOUNTING PREPARATION: MODEL 6691**  
PREPARE MOUNTING SURFACE,  $\phi 1.25$  [31.2] MIN, FLAT TO .001 TIR.  
TAP M6 X 1  $\nabla .200$  [5.1] MIN. TORQUE TO 12-15 Lb-in.

		<b>MASTER</b>	
Chatsworth, CA		ONLY IF IN RED	
TITLE: <b>OUTLINE/INSTALLATION DWG, TRIAxIAL DC ACCELEROMETER, 7503D SERIES</b>			
SIZE <b>B</b>	CAGE CODE <b>2W033</b>	DWG NO <b>127-7503D</b>	REV <b>D</b>
SCALE: 2:1		SHEET 2 OF 2	

Model Number 7503D6	<b>PERFORMANCE SPECIFICATION</b>			DOC NO PS7503D6
	TRIAxIAL VARIABLE CAPACITANCE ACCELEROMETER			REV H, ECN 14692, 11/09/18

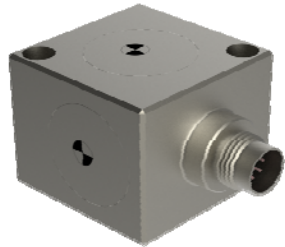

- VARIABLE CAPACITANCE TECHNOLOGY
- ± 4V DIFFERENTIAL OUTPUT
- HERMETICALLY SEALED
- DC RESPONSE

**PHYSICAL**

Weight, Max  
Connector Type  
Material  
Sensing Technology

ENGLISH		SI	
1.3	oz	38	grams
9-pin, 5/16-32 UNEF-2A		9-pin, 5/16-32 UNEF-2A	
Titanium Alloy		Titanium Alloy	
MEMS		MEMS	

**PERFORMANCE**

Input Range  
Frequency Response (±5%)  
Frequency Response (±3dB)  
Resonant Frequency  
Sensitivity Differential, ±5% [1]  
Output Noise, Differential, Typ  
Non-Linearity, Max [2]  
Cross Axis Sensitivity, Max  
Scale Factor Calibration Error, Max.  
Zero Measured Output

±100	g	±981	m/s <sup>2</sup>
0 - 1300	Hz	0 - 1300	Hz
0 - 2500	Hz	0 - 2500	Hz
>3000	Hz	>3000	Hz
40	mV/g	4.1	mV/m/s <sup>2</sup>
100	μg rms/√Hz	981	μ m/s <sup>2</sup> /√Hz
0.5	% F.S	0.5	% F.S
3	%	3	%
1	%	1	%
±50	mV	±50	mV

**ENVIRONMENTAL**

Maximum Mechanical Shock (0.1 ms)  
Bias Temperature Shift, Max [3]  
Bias Calibration Error, Max  
Operating Temperature Range  
Scale Factor Temperature Shift [3]  
Seal

±5000	gpk	±49050	m/s <sup>2</sup> peak
111	(ppm of span)/°F	200	(ppm of span)/°C
0.5	% of span	0.5	% of span
-67 to +257	°F	-55 to +125	°C
-111 to +111	ppm/°F	-200 to +200	ppm/°C
Hermetic		Hermetic	

**ELECTRICAL**

Output Common Mode Voltage, Typ  
Output Impedance  
Operating Voltage  
Operating Current (AOP & AON open), Max  
Power Supply Rejection Ratio  
Ground Isolation

2.5	VDC	2.5	VDC
<10K	Ω	<10K	Ω
+9 to +36	VDC	+9 to +36	VDC
35	mA Dc	35	mA Dc
>65	dB	>65	dB
>30	MΩ	>30	MΩ

**This family also includes:**

Model	Input Range (g)	Frequency Response, ±3dB (Hz)	Sensitivity Differential, ±5% (mV/g)	Max.Shock (0.1ms) g (peak)	Noise Differential (μg/√Hz)
7503D1	±2	0-400	2,000	2000	7
7503D2	±5	0-500	800	2000	12
7503D3	±10	0-1000	400	5000	18
7503D4	±25	0-1400	160	5000	25
7503D5	±50	0-2000	80	5000	50
7503D7	±200	0-3000	20	5000	200
7503D8	±400	0-4000	10	5000	400
7503D9	±5(X&Y), ±25(Z)	0-500(X&Y), 0-1400(Z)	800(X&Y), 160(Z)	2000	12(X&Y), 25(Z)
7503D10	±5(X&Y), ±50(Z)	0-500(X&Y), 0-2000(Z)	800(X&Y), 80(Z)	2000	12(X&Y), 50(Z)

Refer to the performance specifications of the products in this family for detailed description.

**Supplied Accessories:**

- 1) Accredited calibration certificate (ISO 17025)
- 2) Mounting stud, Model 6360, 1/4-28 UNF-2A, Qty 1
- 3) Mounting stud, Model 6691, 1/4-28 UNF-2A to M6 X 1, Qty 1
- 4) Mounting screws, Model 6753A1, 8-32 x 1.0, Qty. 2
- 5) Mounting screws, Model 6687A1, M4x0.7 x 25mm, Qty. 2
- 6) Flat washers, Model 6754, Qty. 2

**Notes:**

- [1] Single ended sensitivity is half of values shown. (Ref. at 100 Hz)
- [2] -90% to +90% of Full Scale.
- [3] Over the rated temperature range.
- [4] In the interest of constant product improvement, we reserve the right to change specifications without notice.

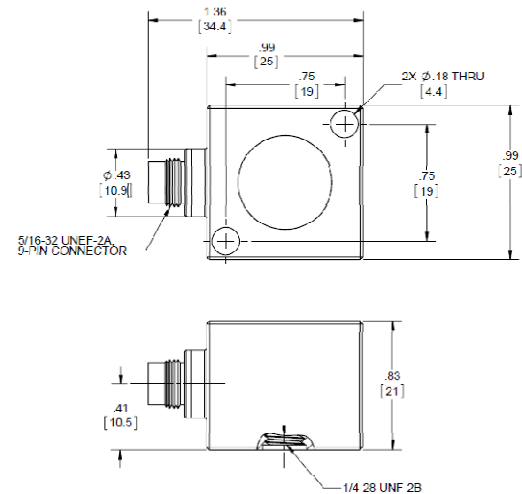

Units on the line drawing are in inches. Refer to 127-7503D for more information.

